



VAR INDUSTRY
**COMPACT DOUBLE
 DOOR**



9

The fully closed in- or outdoor waste collector suitable for 120 l garbage bags. The device is manufactured from galvanized steel sheets with a solid bottom and a metal lid.

Available with foot pedal (Art.-No. 1081), only in green.

Due to the processed materials the device is fire-proof.

The double swing doors provide for an easy and uncomplicated change of the garbage bags.

The device is available in eight different colors, with high-quality powder coating (Art.-No.'s please see the back side).

Opening ca. 395mm

Accessories are a moving base (Art.-No. 1156) with five wheels and 120l garbage bags (Art.-No. 1121), VE=250 pcs.





COMPACT DOUBLE DOOR

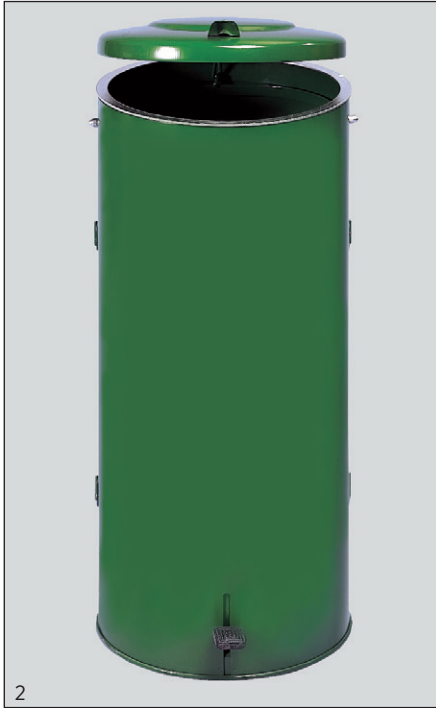

Pic.: Compact double door pedal, green coated, Art.-No. 1081, with practical foot pedal (only available in green)

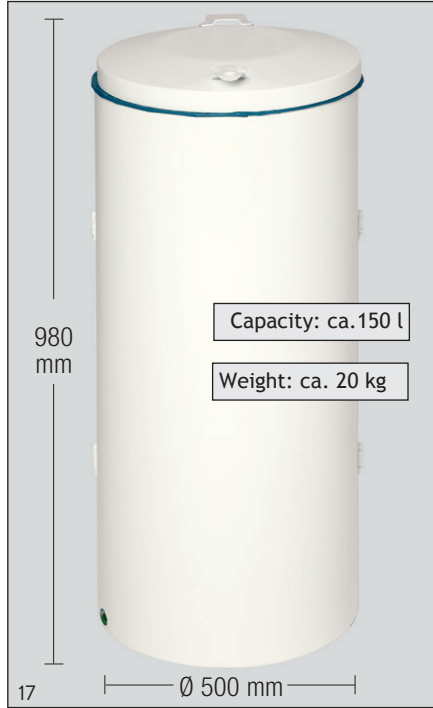

Pic.: Compact double door, white coated, Art.-No. 1061



Pic.: Compact double door, yellow coated, Art.-No. 1066

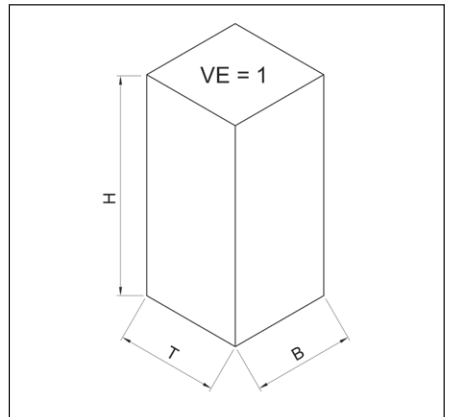

| H x D x W (mm) | |
|----------------|--------------------|
| C.-doubledoor | = 1050 x 460 x 450 |
| Moving base | = 185 x 455 x 455 |
| Garbage bags | = 230 x 380 x 300 |



Pic.: Moving base, stainless steel, 5 wheels, Art.-No. 1156

| Article description | (RAL) | white (9016) | flame red (3000) | anthracite (7021) | emeraldgreen (6001) |
|---------------------|----------|---------------|---------------------|-------------------|---------------------|
| Compact double door | Art.-No. | 1061 | 1062 | 1064 | 1080 |
| Article description | (RAL) | yellow (1023) | gentian blue (5010) | silver | antique silver |
| Compact double door | Art.-No. | 1066 | 1069 | 1087 | 10642 |

